

### Principle Applications

Designed for continuous recirculation of carbonated water, aggressive chemicals, chilled water, pure or precious liquids in high pressure systems.

### Features

- Manufactured from chemically resistant thermoplastics
- Operating at an optimum flow rate of 3 litres/minute
- Magnetic coupling provides an energy efficient thermal shield, Minimising heat transfer to the pumped fluid.
- Temperature stability and product purity ensured
- Leak free continuous operation
- IPX5 motor housing
- Low condensation
- Nitrile o rings standard. Other materials available
- Zero maintenance
- PPS pump head
- Long life

### Options

#### Voltage Options

230V 1Ph 50/60Hz

110V 1Ph 50/60Hz

#### Port Options

1/2" OD

15mm OD

## Installation

Drawings not to scale  
Dimensions in millimetres

# HPR6/11

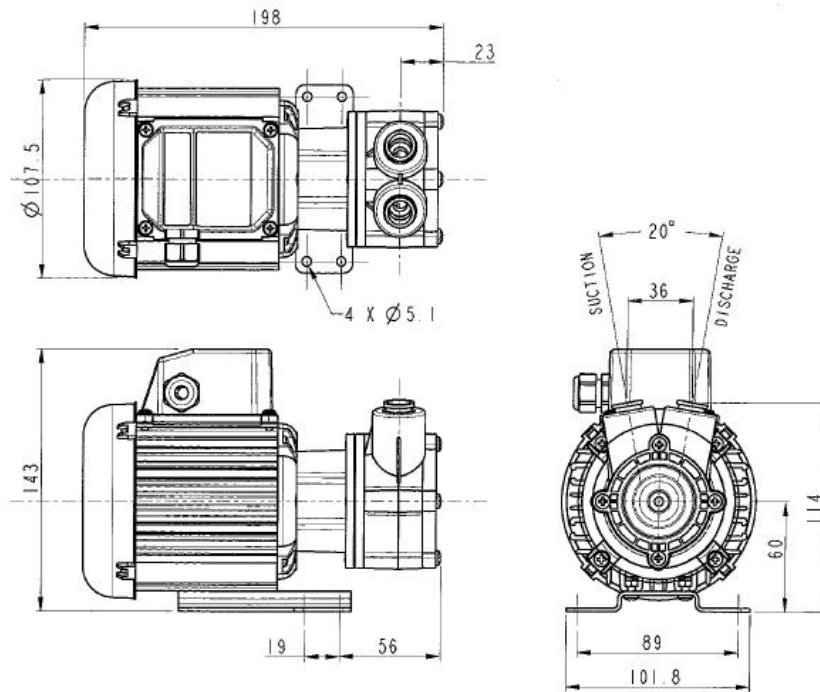

## Specification

Model	Overall height (mm)	Overall length (mm)	Overall width (mm)	Weight (kg)	Max body pressure (bar)	Run-out flow rate (l/min)	Closed valve head (m)	Temp range (degC)	*Max specific gravity	Motor output (watts)
HPR6/11	143	198	102	2.6	10	50Hz 6.2	10.5	-20 to +85	1.2	35
						60Hz 7.3	13			

\*Assuming maximum viscosity of 30cp. Refer to Totton Pumps for higher viscosities and specific gravities

## Performance

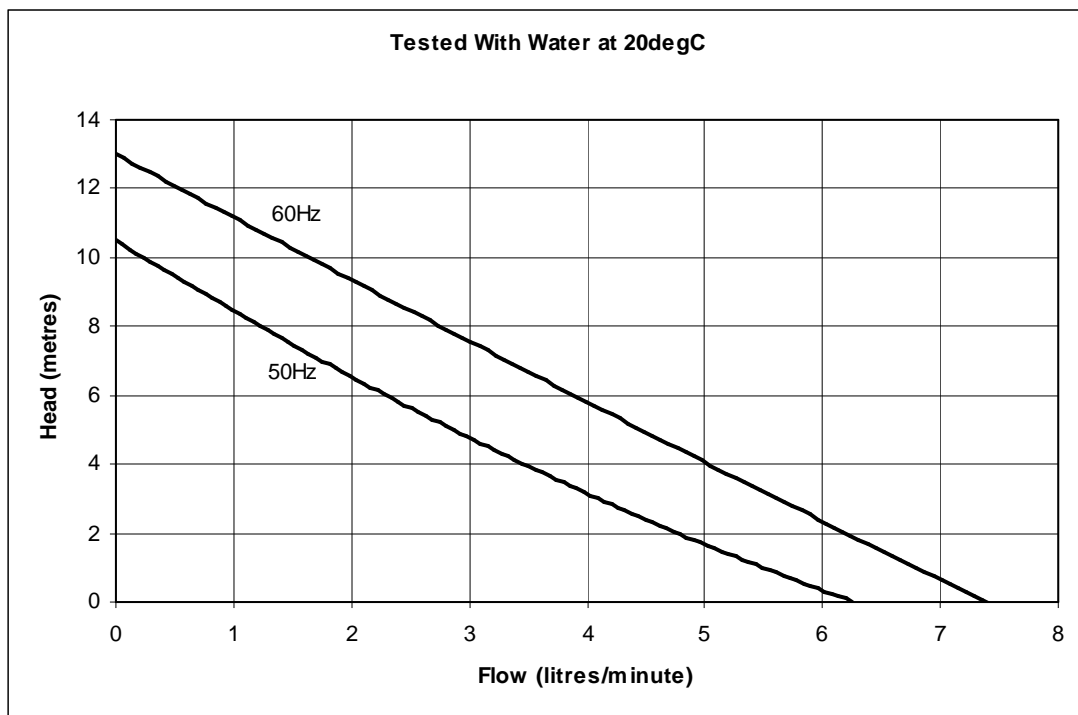

Note: These magnetically coupled pumps are designed for use with clean fluids. Solids will cause jamming. Abrasives will reduce pump life and invalidate warranty. These HPR pumps are not designed to run dry. The company reserves the right change specifications.

Part List

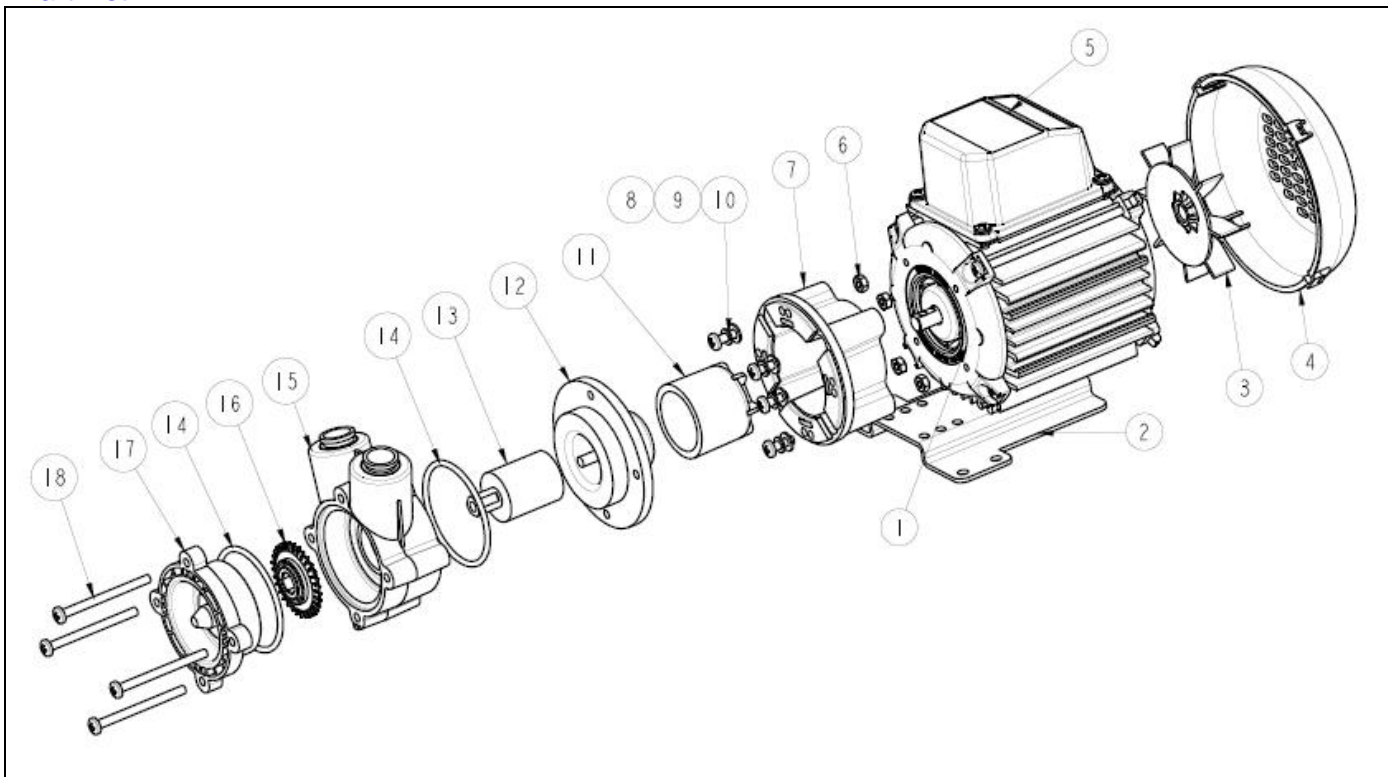

Item Number	Description	Quantity	Part Number		
1	Motor	1	116849 (230V 50/60Hz)		116874 (110V 50/60Hz)
2	Mounting Foot	1	036329		
3	Fan	1	001577		
4	Fan Cowl	1	036085		
5	Terminal Box	1	036078		
6	Nut	4	032105		
7	Adaptor	1	036344		
8	Screw	4	022163		
9	Washer	4	031215		
10	Washer	4	001565		
11	Drive Magnet	1	043311 8mm Bore	023267 6mm Bore	
12	Spindle Housing	1	033276		
13	Driven Magnet	1	033248		
14	O Ring	2	013394 Nitrile	013291 EPDM	003265 Viton
15	Pump Body	1	033321 1/2"OD Ports	033320 15mm OD Ports	043310 3/8" ID Ports
16	Impeller	1	033323		
17	Front Cover	1	033249		
18	Screw	1	022270		

**Totton Pumps Ltd.**

Tel: +44 (0) 23 8066 6685

Fax: +44 (0) 23 8066 6880

Email: [info@totton-pumps.com](mailto:info@totton-pumps.com)

Web: [www.totton-pumps.co.uk](http://www.totton-pumps.co.uk)