

Principle Applications

Designed for continuous operation in, chillers, coolers, vending and general water applications

Pipes, Fittings and Mounting Plates

SPC pumps are fitted to python systems to provide the optimum cooling rate for soft drinks, beers and wines

Braided hose or brewery tubing complete with fittings available to order

Alternative mounting plates in stainless steel available to order

Wetted Materials

Stainless steel mounting plate
ABS/PP/Nylon Column/Pump Body
Stainless steel shaft
Nylon Agitator

Features

Up to 13 litres/minute,

Up to 3.5 metres head

Low maintenance and long life

Available with plugs and leads to suit application

Agitator propeller fitted as standard

Options

110 or 230V 50/60Hz

Installation

Drawings not to scale
 Dimensions in millimetres

SPC12/4

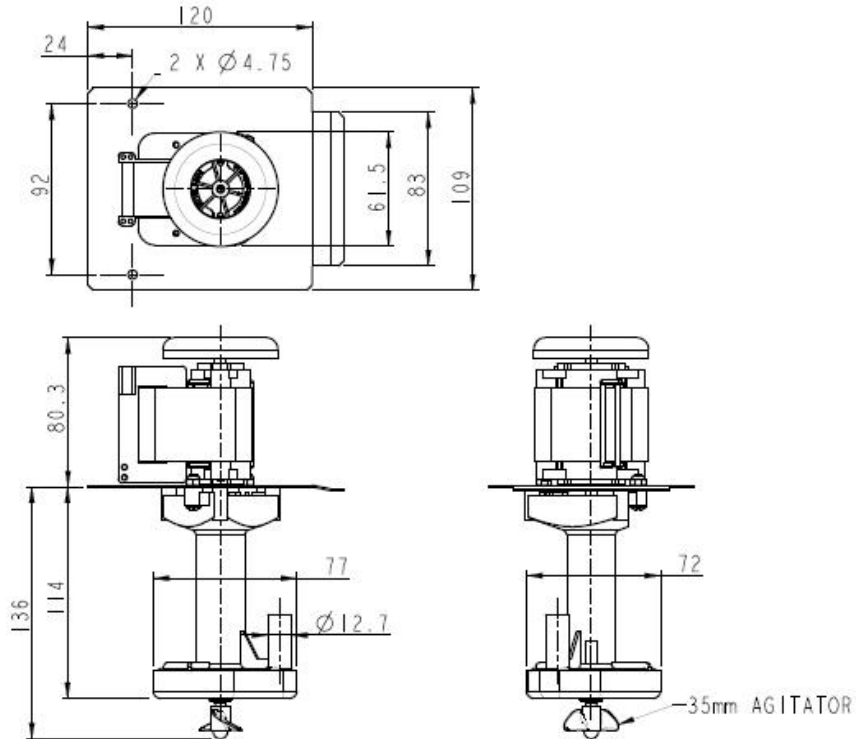

Specification

Model	Overall height (mm)	Overall length (mm)	Overall width (mm)	Weight (kg)	Run-out flow rate (l/min)	Closed valve head (m)	Outlet Port (mm)	Temp range (degC)	*Max specific gravity	Motor output (watts)
SPC12/4	80.3	216.3	109	1.4	13	3.5	12,5	-20 to +85	1.2	10

*Assuming maximum viscosity of 30cp. Refer to Totton Pumps for higher viscosities and specific gravities

Performance

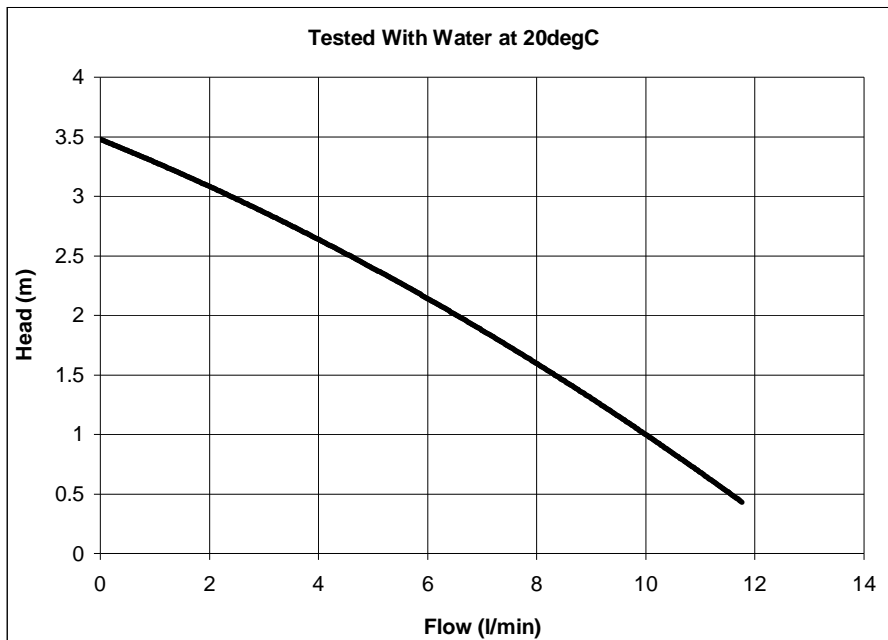

NOTE: These pumps are designed for use with clean fluids.

Solids will cause jamming. Abrasives will reduce pump life & invalidate the warranty. SPC pumps are self-priming. The company reserves the right to change specifications

Totton Pumps Ltd.

Tel: +44 (0)23 8066 6685
 Email: info@totton-pumps.com

Fax: +44 (0)23 8066 6880
 Web: www.totton-pumps.co.uk