

### Principal Applications

Designed for continuous operation in, chillers, coolers, vending and general water applications

### Pipes, Fittings and Mounting Plates

SPC pumps are fitted to python systems to provide the optimum cooling rate for soft drinks, beers and wines

Braided hose or brewery tubing complete with fittings available to order  
Universal mounting plate to fit all major manufacturers' coolers

### Wetted Materials

Nylon mounting plate  
Glass filled ABS Column & Pump Body with PP Impellers,  
Stainless steel shaft & Nylon Agitator

### Features

Up to 17.8 litres/minute,  
Up to 18.3 metres head  
Three stage pump head  
Low maintenance and long life  
Ø68mm 3 blade agitator propeller fitted as standard  
Motor features:  
IPX5 enclosure  
1m cable lead with IEC plug  
Unpainted end frames & extrusion - fixings at fan end - for ease of refurbishment  
2 rubber sealed bearings with inner races press-fitted to shaft

### Voltage

110V or 230V 50/60Hz versions

## Installation

Drawings not to scale  
Dimensions in millimetres

## SPC17/18 Universal

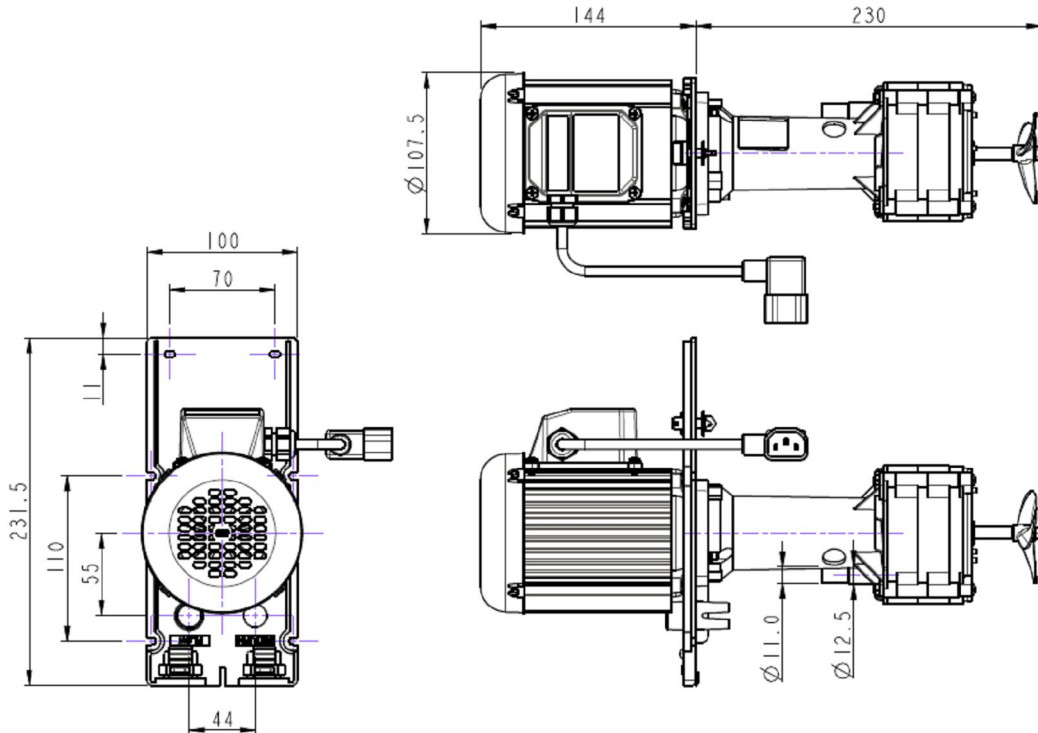

## Specification

Model	Overall height (mm)	Overall length (mm)	Weight (kg)	Run-out flow rate (l/min)	Closed valve head (m)	Output port (mm)	Temp range (degC)	*Max specific gravity	Motor output (watts)
SPC17/18 Universal	144	374	3.3	17.8	18.3	Plain 11/12.5 combined	-20 to +85	1.0	90

\*Assuming maximum viscosity of 30cp. Refer to Totton Pumps for higher viscosities and specific gravities

## Performance

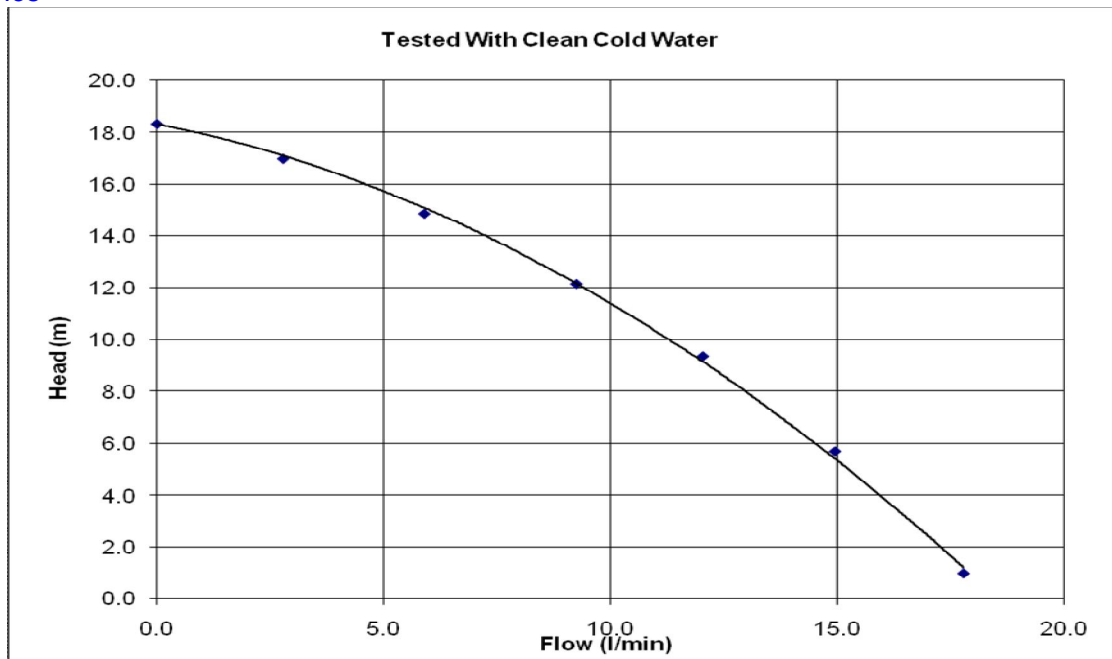

**NOTE:** These pumps are designed for use with clean fluids.

Solids will cause jamming. Abrasives will reduce pump life & invalidate the warranty. SPC pumps are self-priming. The company reserves the right to change specifications

### Totton Pumps Ltd.

Tel: +44 (0)23 8066 6685  
Email: [info@totton-pumps.com](mailto:info@totton-pumps.com)

Fax: +44 (0)23 8066 6880  
Web: [totton-pumps.co.uk](http://totton-pumps.co.uk)