

Principle Applications

Hot and cold drinks vending machines, where the sealless design ensures the purity of vended liquid, preventing contaminants introducing bacteria or taste taint.

Wetted Materials

PP Pump Body
Stainless steel spindle
Nitrile or Silicone 'O' ring

Features

Low power consumption
Variable mounting foot positions
Customer choice of plug & lead length
Designed for a minimum 5 years normal operation

Options

VM35/3
230V 1ph 50/60 Hz
230V 1ph 50/60 Hz

Port Details
Plain 21 mm
1/2" BSP M

VM35/3
110V 1ph 50/60 Hz
110V 1ph 50/60 Hz

Port Details
Plain 21 mm
1/2" BSP M

Installation

Drawings not to scale
 Dimensions in millimetres

VM35/3

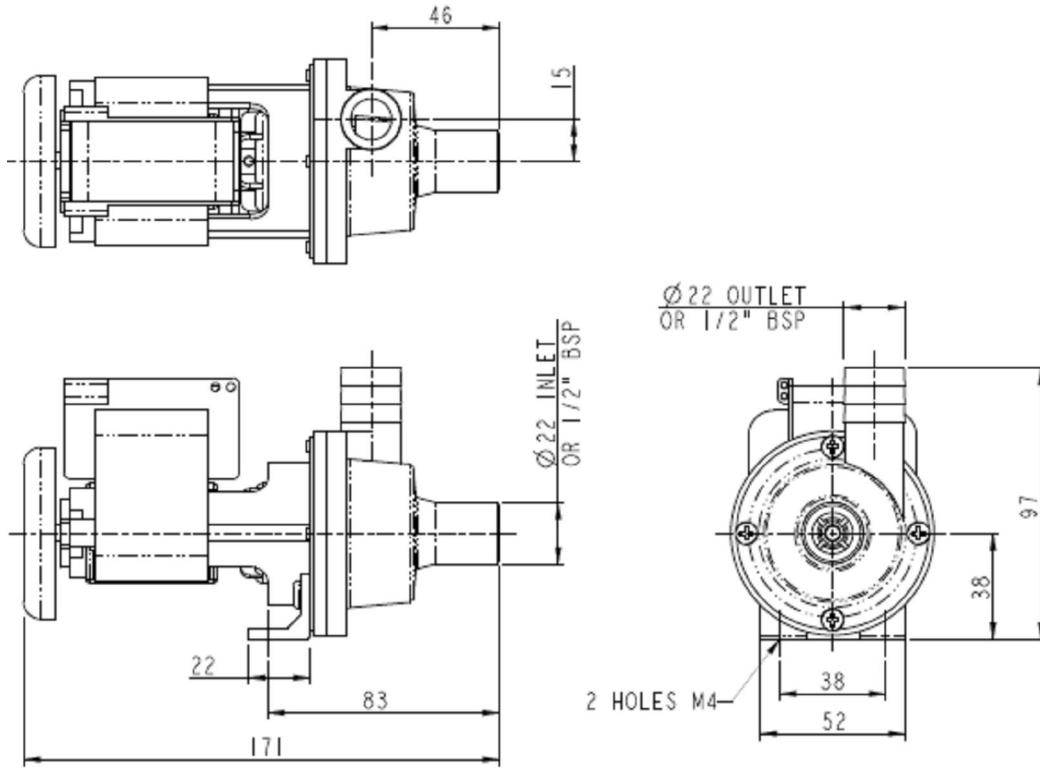

Specification

Model	Overall height (mm)	Overall length (mm)	Overall width (mm)	Weight (kg)	Max body pressure (bar)	Run-out flow rate (l/min)	Closed valve head (m)	Temp range (degC)	*Max specific gravity	Motor output (watts)
VM35/3	97	171	73	1.6	1.4	50 Hz 35	2.1	-20 to +85	1.2	18
						60 Hz 33	3.3			

*Assuming maximum viscosity of 30cp. Refer to Totton Pumps for higher viscosities and specific gravities

Performance

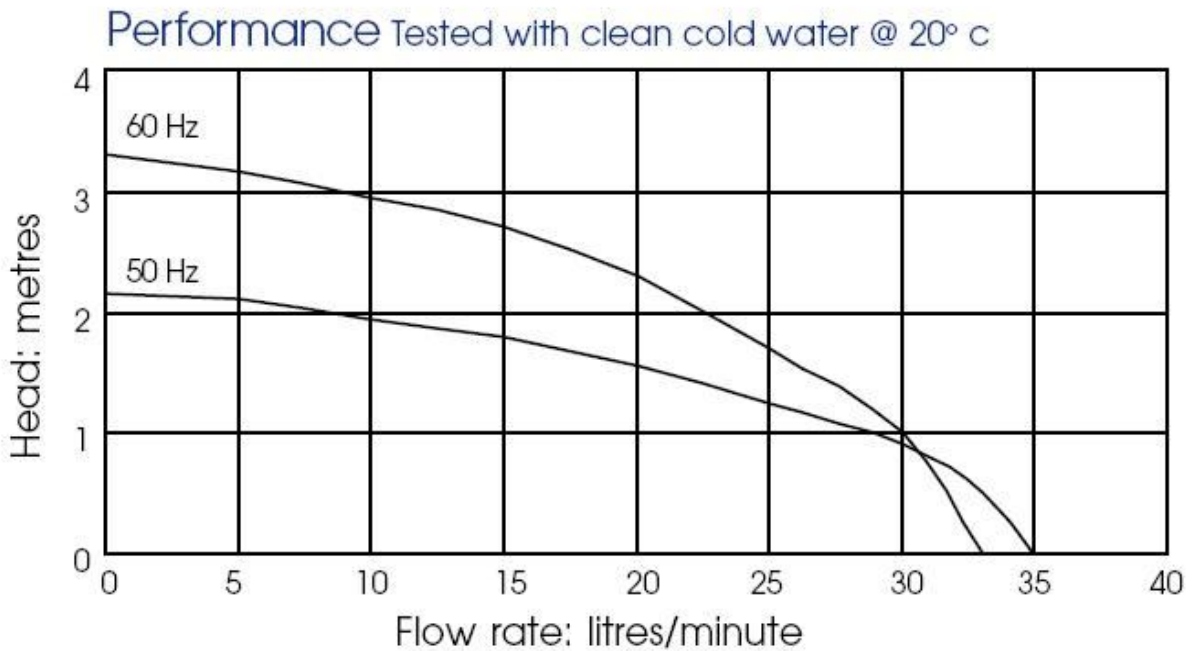

VM pumps are not self-priming and are not designed to run dry.
 The company reserves the right change specifications.

Part List

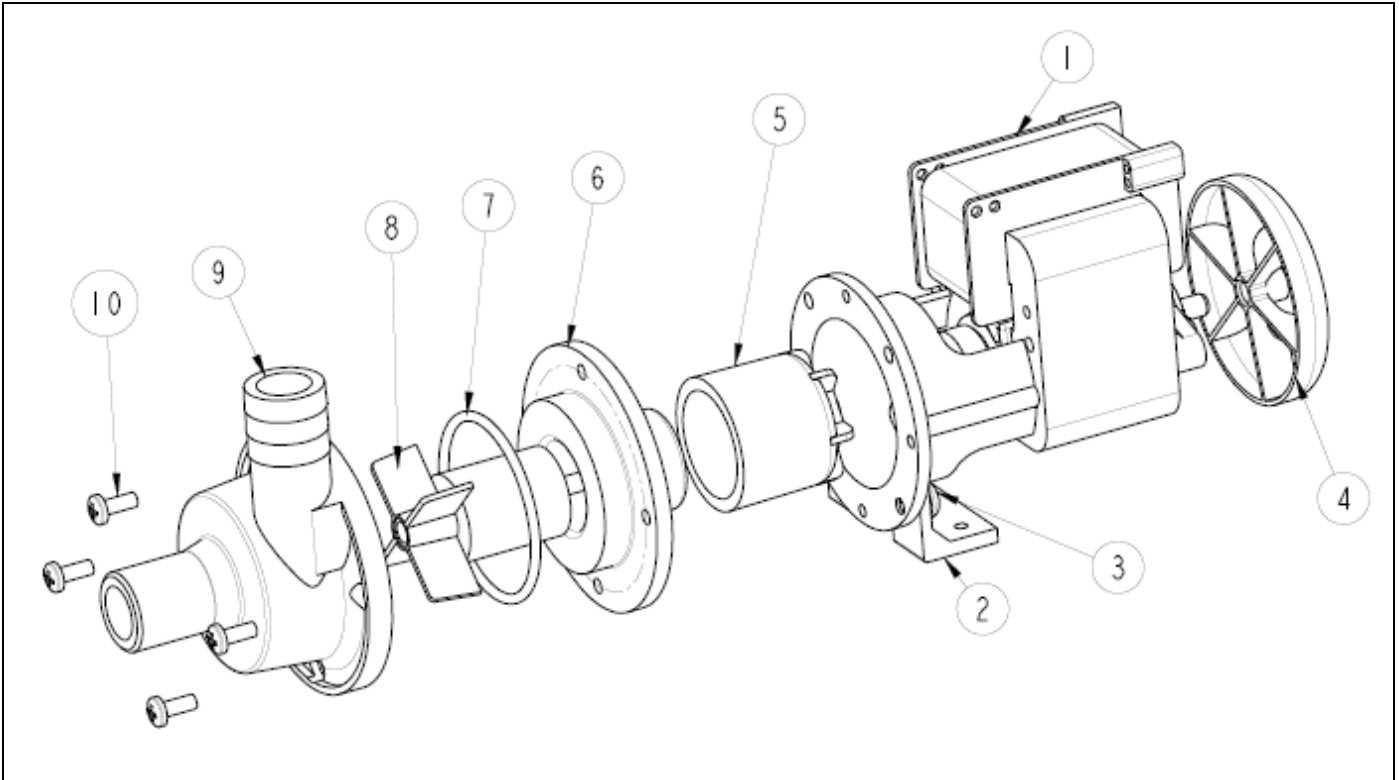

Item Number	Description	Quantity	Part Number	
1	Motor	1	-	
2	Mounting Bracket	1	003366	
3	Screw	1	021096	
4	Fan	1	033322	
5	Drive Magnet	1	023267	
6	Spindle Housing	1	003357	
7	O-ring	1	003224 (Nitrile)	023224 (Silicone)
8	Impeller	1	003282 (50 Hz)	003279 (60 Hz)
9	Pump Body	1	013333 (plain)	013334 (threaded)
10	Screw	4	001652	

Totton Pumps Ltd.
 Tel: +44 (0) 23 8066 6685
 Fax: +44 (0) 23 8066 6880
 Email: info@totton-pumps.com
 Web: www.totton-pumps.co.uk